

ZK-6421

智能天地盖制盒机
Intelligent
Rigid Box Making
Machine



本机采用伺服控制系统、可编程运动控制器系统、视觉+机器人定位系统、人机界面整机智能化系统，实现智能化操作功能，数字化调节方式和参数化功能设置。采用独创盒高自动调节功能及伺服线性导轨调节功能，实现机器的定位精度高、更换规格易调节、运行更稳定、动作更流畅和生产效率更高。纸盒自动送面纸、上胶、定位贴合、引取、裱盒、包边、全折耳和折入成型动作一次性完成的特点。使用于高档精品天地盖纸盒生产，如电子产品包装盒、手机盒、珠宝盒、化妆品盒、手表盒、斜边盒、书型盒、礼品盒等。

This machine adopts servo control system, programmable motion controller system, vision + robot positioning system, and man-machine interface intelligent system to realize intelligent operation functions, digital adjustment methods and parameterized function settings. The original box height automatic adjustment function and servo linear guide adjustment function are used to achieve high positioning accuracy of the machine, easy adjustment of replacement specifications, more stable operation, smoother movement and higher production efficiency. paper feeding, gluing, cardboard four corners taping, feeding, edge covering, full ear folding, forming and shaping of the finished box are completed in one operation. So it is applicable to the production of high-end rigid boxes, such as business package boxes for electronic products, mobile phone boxes, jewelry boxes, gift boxes, cosmetics boxes, watch box, bevel box, slip case box and so on.

产品技术参数	Specifications	
面纸尺寸	Cover paper size	
长	A	180-850mm
宽	B	100-620mm
盒子尺寸	Box size	
长	L	80-600mm
宽	W	40-400mm
高	H	15-210mm
内包边尺寸	Turn in depth size	
内包	R	15-100mm
折耳尺寸	Ear folding size	
折耳	E	15-125mm
面纸规格	Grammage	
纸板厚度	Cardboard thickness	
厚度	T	0.8-3mm

注：1. 盒子大小规格受面纸尺寸的约束；
2. 盒宽小于200mm时需更换小规格配件；
3. 选配在线胶水粘度检测系统；
4. 本司不提供空气压缩机；
5. 影响机器速度的几个因素：原材料，胶水和操作者的熟练程度；
6. 由于产品设计不断创新，以上数据仅供参考；如有变更恕不另行通知。

设备技术参数	Technical parameters	
速度	Speed	15-35 Pcs/min
控制系统	Control system	运动控制器 Motion controller
对位配置	Alignment configuration	视觉系统 Visual system
定位机构	Positioning mechanism	机械手 Manipulator
定位精度	Precision error	± 0.05mm
面纸堆放高度	Paper pile height	700mm
纸板堆放高度	Cardboard pile height	1000mm
电源	Power supply	380V 50Hz
功率	Electrical power	36Kw
气源	Air supply	460L/min 0.6MPa
胶水桶容量	Glue tank capacity	45L
机器净重	Net weight	8800Kg
机器尺寸	Overall dimension	7100mm × 4400mm × 3800mm

Note: 1. The size of the box is restricted by the size of the cover paper;
2. The box width less than 200mm needs to add small specifications accessories;
3. Online viscometer system(optional)
4. The company does not provide air compressors;
5. Several factors that affect the speed of the machine: raw materials, glue and operator proficiency;
6. Due to continuous innovation in product design, the above data is for reference only, and are subject to change without notice.

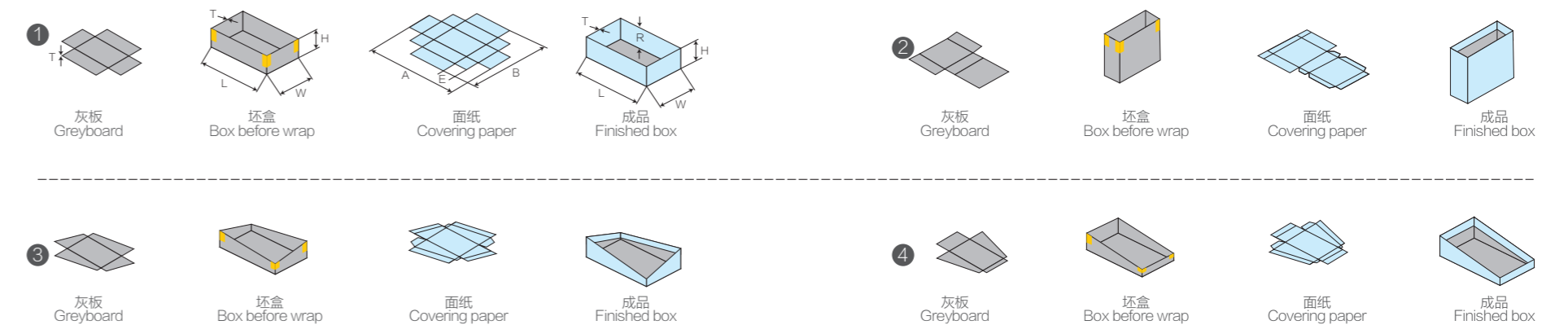

操作范围 Operating range $A(\text{Min}) \leq L+2H+2T+2R \leq A(\text{Max.})$ $B(\text{Min}) \leq W+2H+2T+2R \leq B(\text{Max.})$